

# OWNER'S MANUAL TRIUMPH STREET TRIPLE

245-017-250-010

# 765 RS



## INTRODUCTION

The DDS Lite Rear Shock Absorber has been designed for use at the highest levels of racing and developed in major championships around the world. Like all other K-Tech products it has been designed and manufactured in the UK using the latest software and highest grade materials and processes available.

The championship winning Direct Damping System provides incredible performance and precise tuning for ultimate chassis control in the most demanding conditions of racing shock absorber. The DDS Lite comes with the following specifications listed as standard:

Preload Adjustment  
Compression Adjustment  
Rebound Adjustment  
Length Adjustment

**\*\*\*This product is not designed or intended for highway use\*\*\***

K-Tech Suspension Ltd products are manufactured to fit specific brands and models. Under no circumstances should any K-Tech Suspension Ltd products be fitted to an application other than that for which it has been designed, tested and manufactured.

## RECOMMENDED SETTINGS

Shock length	283(-/+3mm)
Shock stroke	60mm
Spring Rate	100N/m
Spring Preload	12mm
Comp damping (Black)	12 Clicks Out
Reb damping (Natural)	12 Clicks Out

## ADJUSTMENT

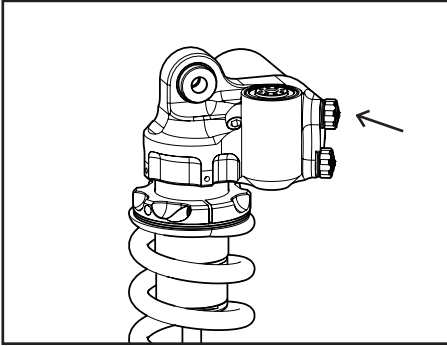

### **Compression damping:-**

Black Adjuster Wheel:- 32 clicks adjustment range. All settings should be made from the fully closed (Clockwise Position).

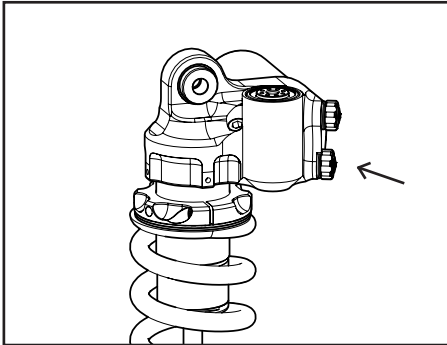

### **Rebound damping:-**

Natural Adjuster Wheel:- 32 clicks adjustment range. All settings should be made from the fully closed (Clockwise Position).

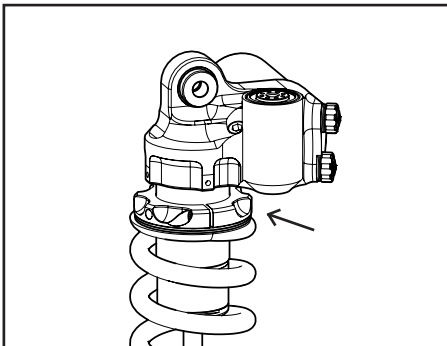

### **Spring preload:-**

Remove securing screw before adjusting preload.

To add preload turn clockwise.

To remove preload turn anti-clockwise.

1 turn = 1.5mm

Always tighten the securing screw after preload has been modified.

## ADJUSTMENT

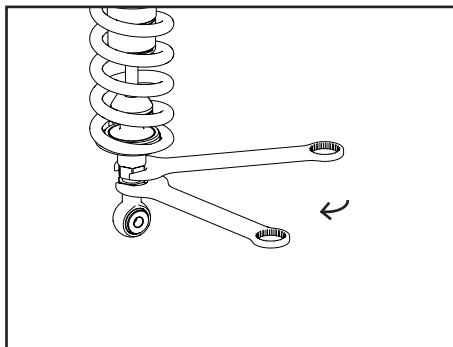

### Shock length:-

To adjust the shock length, loosen the silver lock nut at the bottom of the shock with a 24mm open ended spanner whilst holding the piston rod joiner assembly (Black 24mm nut) with another spanner.

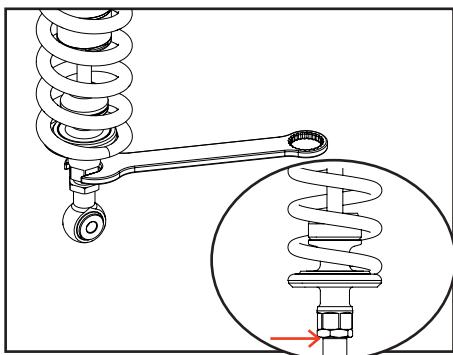

### Shock length:-

Turn the Rod Joiner using a 24mm spanner to get the desired shock length.

**N.B.** 1 full turn changes the shock length by 1mm.



**Do not extended the length of the shock to the point that the safety groove is visible below the locking nut.**

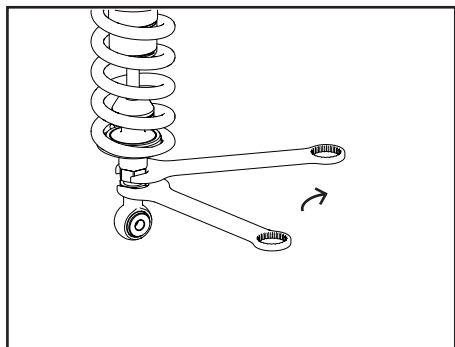

### Shock length:-



When you have changed the shock length re-tighten the silver lock nut to the rod joiner using the two 24mm spanners and torque to 30N/m.

## FITTING THE SHOCK

**This procedure should only be carried out by a qualified motorcycle technician. K-Tech Suspension Ltd will not be liable for any damages caused to or by the product, nor be liable for any injuries sustained if the product is fitted by an un-authorised dealer of K-Tech Suspension Ltd. K-Tech Suspension Ltd will not be liable for any damages if the correct tools are not used throughout the entire process of fitting and adjusting the Shock.**

**Please refer to the manufacturer's workshop manual before attempting this procedure. This procedure will require two people. You will need to remove all relevant bodywork and any other parts that may restrict you from carrying out this task safely.**

Place and secure the motorcycle on an appropriate stand so that the wheel is approximately 5cm off the ground.

Loosen top and bottom mounting bolts using the correct spanners.

With one person holding the rear wheel in a stationary position the second person can remove the top bolt, it may be necessary to slightly move the rear wheel up and down whilst removing the top bolt.

Keeping the rear wheel in a stationary position the second person can now remove the bottom bolt, it will be necessary to hold the shock whilst doing this.

Remove the shock from the bike keeping the rear wheel stationary while doing so. You are now ready to fit the K-Tech rear shock.

Place the shock into the bike fitting the bottom mounting bolt first, it may be necessary for the second person to slowly move the rear wheel up or down for you to insert the bolt through any linkages.

Now fit the top mounting bolt and torque both top and bottom bolts to the manufacturer's recommendations.

**Take a slow test drive to make sure that everything is correct.**

## SERVICE

K-Tech Suspension Ltd recommend that this product is serviced every 20 hours of use. It is very important that this product is serviced by an authorised dealer, as there are special tools required to guarantee correct performance of this product. K-Tech Suspension Ltd cannot be held responsible for any damage caused to/by the product if a service is overdue or was not conducted by an authorised dealer.

## WARNING

This procedure should only be carried out by a qualified motorcycle technician. K-Tech Suspension Ltd will not be liable for any damages caused to or by the product, nor be liable for any injuries sustained if the product is fitted by an un-authorised dealer of K-Tech Suspension Ltd. K-Tech Suspension Ltd will not be liable for any damages if the correct tools are not used throughout the entire process of fitting and adjusting the Shock.

Please refer to the manufacturer's workshop manual before attempting this procedure. This procedure will require two people. You will need to remove all relevant bodywork and any other parts that may restrict you from carrying out this task safely.

## NOTES

---

---

---

---

---

---

---

---

---

---

---

---





[www.ktechsuspension.com](http://www.ktechsuspension.com)

Contact your local K-Tech dealer for more details at  
[www.ktechsuspension.com/service-centres-and-partners](http://www.ktechsuspension.com/service-centres-and-partners)