

# OWNER'S MANUAL

# HONDA CRF 300L

287SD-021-130-VAR



## CONTENTS

Page 2	Introduction/Service
Page 3-4	Adjustment
Page 5	Fitting the shock
Page 6-7	Settings/Notes

## INTRODUCTION

Multiple adjustment, improved control, refinement and awesome looks make K-Tech Razor shocks a leap beyond standard equipment.

The Razor range of shock absorbers are available in multiple lengths with 2 way adjustability allowing you to customise your motorcycle for looks and riding style.

- Increased comfort and control
- Up to 2 way adjustability
- Nitrogen Filled (N<sup>2</sup>)
- Anodised black finish
- Optional spring rates

K-Tech Suspension Ltd products are manufactured to fit specific brands and models. Under no circumstances should any K-Tech Suspension Ltd products be fitted to an application other than that for which it has been designed, tested and manufactured.

## ADJUSTMENT

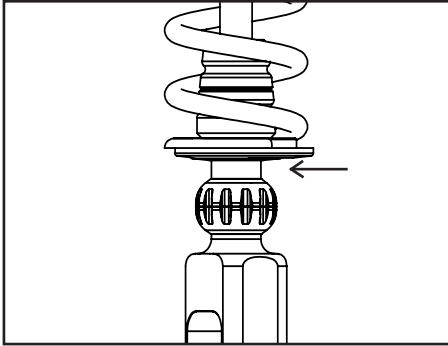

Rebound damping:-  
Bottom Adjuster Wheel:- 32 clicks adjustment range. All settings should be made from the fully closed (Clockwise Position).

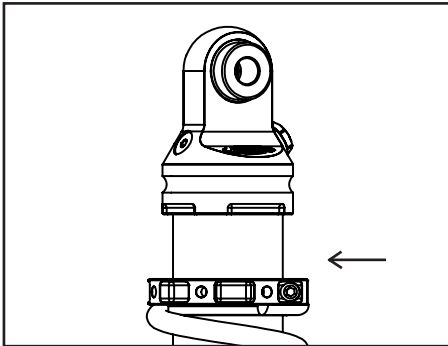

Spring preload:-  
To adjust, loosen the pinch bolt on the Spring Collar using a 3mm allen key. Then, turn the collar using your K-Tech Preload Adjuster Tool (213-235-305) (1 turn = 1.5mm).



Secure by tightening the the pinch bolt to 5Nm using a 3mm allen key.

## FITTING THE SHOCK

This procedure should only be carried out by a qualified motorcycle technician. K-Tech Suspension Ltd will not be liable for any damages caused to or by the product and will not be liable for any injuries sustained if the product is fitted by an un-authorized dealer of K-Tech Suspension Ltd. K-Tech Suspension Ltd will also not be liable for any damages if the correct tools are not used throughout the process of fitting and adjusting a K-Tech suspension Ltd product.

Please refer to the manufacturer's workshop manual before attempting this procedure. This procedure will require two people. You will need to remove all relevant bodywork and any other parts that may restrict you from carrying out this task safely.

Place and secure the motorcycle on an appropriate stand so that the wheel is approximately 5cm off the ground. Loosen the top and bottom mounting bolts using the correct spanners. With one person holding the rear wheel in a stationary position the second person can remove the top bolt, it may be necessary to slightly move the rear wheel up and down whilst removing the top bolt. Keeping the rear wheel in a stationary position the second person can now remove the bottom bolt, it will be necessary to hold the shock whilst doing this. Remove the shock from the bike keeping the rear wheel stationary while doing so.

You are now ready to fit the K-Tech Razor shock.

Place the shock into the bike, fitting the bottom mounting bolt first. It may be necessary for the second person to slowly move the rear wheel up or down for you to insert the bolt through any linkages.

Fit the top mounting bolt and torque both top and bottom bolts to the manufacturer's recommendations.

**Take a slow test drive to make sure that everything is correct.**

## SETTINGS

### RECOMMENDED:

Shock length	413mm
Shock stroke	85mm
Gas Pressure	12 bar

PART No.	SPRING	RATE (N/mm)	PRELOAD	REB CLICKS
287SD-021-130-009	46-220-085	85	12mm	24
287SD-021-130-010	46-220-095	95	11mm	24
287SD-021-130-011	46-220-110	110	10mm	20
287SD-021-130-012	46-220-120	120	9mm	16

## SERVICE

K-Tech Suspension Ltd recommend that this product is serviced every 10,000 miles of use. It is very important that this product is serviced by an authorised dealer, as there are special tools required to guarantee correct performance of this product. K-Tech Suspension Ltd cannot be held responsible for any damage caused to/by the product if a service is overdue or was not conducted by an authorised dealer.

[www.ktechsuspension.com/service-centres-and-partners](http://www.ktechsuspension.com/service-centres-and-partners)







[www.ktechsuspension.com](http://www.ktechsuspension.com)

Contact your local K-Tech dealer for more details at  
[www.ktechsuspension.com/service-centres-and-partners](http://www.ktechsuspension.com/service-centres-and-partners)