

# OWNER'S MANUAL YAMAHA R7

279S-021-270-VAR



## CONTENTS

Page 2	Introduction/Service
Page 3-4	Adjustment
Page 5	Fitting the shock
Page 6-7	Settings/Notes

## INTRODUCTION

Multiple adjustment, improved control, refinement and awesome looks make K-Tech Razor shocks a leap beyond standard equipment.

The Razor range of shock absorbers are available in multiple lengths with up to 4 way adjustability allowing you to customise your motorcycle for looks and riding style.

- Increased comfort and control
- Up to 4 way adjustability
- Nitrogen Filled (N<sup>2</sup>)
- Anodised black finish
- Optional spring rates

K-Tech Suspension Ltd products are manufactured to fit specific brands and models. Under no circumstances should any K-Tech Suspension Ltd products be fitted to an application other than that for which it has been designed, tested and manufactured.

ADJUSTMENT

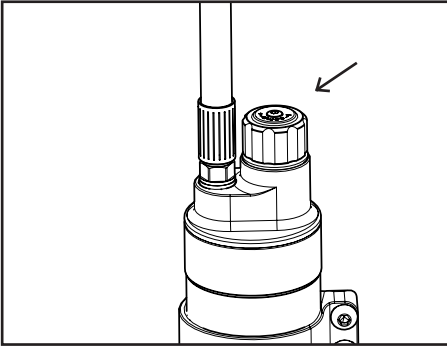

Compression damping:-  
 Black Adjuster Knob:- 30 clicks  
 adjustment range. All settings should be  
 made from the fully closed  
 (Clockwise Position).

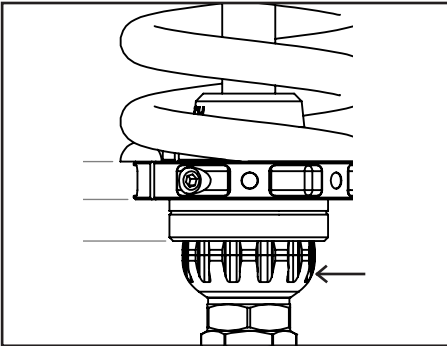

Rebound damping:-  
 Bottom Adjuster Wheel:- 32 clicks  
 adjustment range. All settings should be  
 made from the fully closed  
 (Clockwise Position).

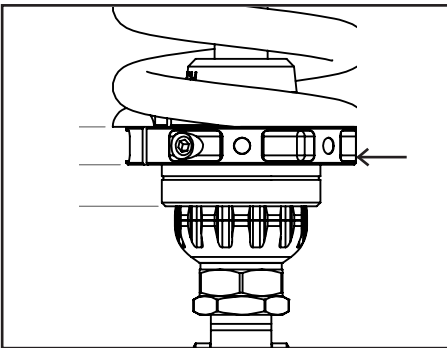

Spring preload:-  
 To adjust -unscrew the pinch bolt on the  
 bottom spring collar using a 3mm Hex  
 Key. Turn the bottom collar using tool  
 213-235-315 (1 turn = 1.5mm).



Secure by tightening the  
 pinch bolt to 5Nm

## ADJUSTMENT

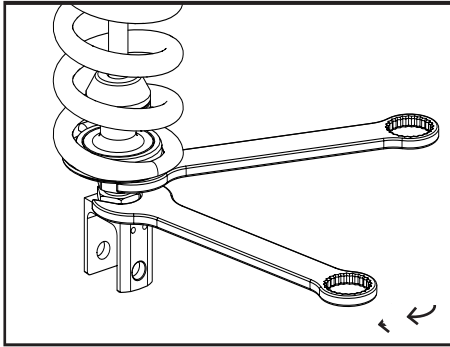

Shock length:-

To adjust the shock length loosen the silver lock nut at the bottom of the shock with a 22mm open ended spanner whilst holding the rod joiner (black 22mm hex) with another spanner.

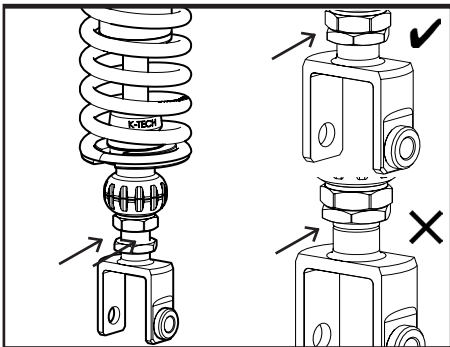

Shock length:-

Turn the end eye assembly until you get the desired length.  
(1 turn = 1mm adjustment.)



Make sure you cannot see the groove on the thread.

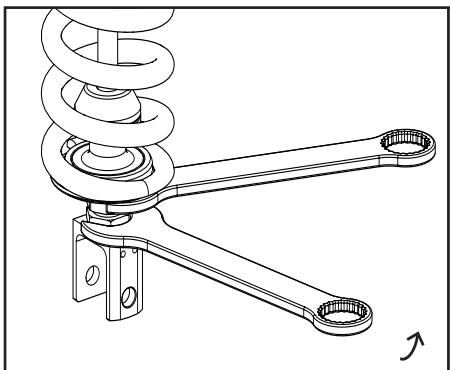

Shock length:-

When you have changed the shock length wind the silver lock nut up to the black rod joiner and torque to 30Nm.

## FITTING THE SHOCK

This procedure should only be carried out by a qualified motorcycle technician. K-Tech Suspension Ltd will not be liable for any damages caused to or by the product, nor be liable for any injuries sustained if the product is fitted by an un-authorized dealer of K-Tech Suspension Ltd. K-Tech Suspension Ltd will not be liable for any damages if the correct tools are not used throughout the entire process of fitting and adjusting the Shock.

Please refer to the manufacturer's workshop manual before attempting this procedure. This procedure will require two people. You will need to remove all relevant bodywork and any other parts that may restrict you from carrying out this task safely.

Place and secure the motorcycle on an appropriate stand so that the wheel is approximately 5cm off the ground. Loosen the top and bottom mounting bolts using the correct spanners. With one person holding the rear wheel in a stationary position the second person can remove the top bolt, it may be necessary to slightly move the rear wheel up and down whilst removing the top bolt. Keeping the rear wheel in a stationary position the second person can now remove the bottom bolt, it will be necessary to hold the shock whilst doing this. Remove the shock from the bike keeping the rear wheel stationary while doing so.

You are now ready to fit the K-Tech Razor shock.

Place the shock into the bike, fitting the bottom mounting bolt first. It may be necessary for the second person to slowly move the rear wheel up or down for you to insert the bolt through any linkages.

Fit the top mounting bolt and torque both top and bottom bolts to the manufacturer's recommendations.

To attach the remote reservoir, remove pillion footrest hanger bolts and fit the reservoir bracket in between the hanger and the rear subframe.

Re-use the original bolts for the footrest hanger and torque to manufacturer's recommendations.

**Take a slow test drive to make sure that everything is correct.**

## SETTINGS

### RECOMMENDED:

Shock length	310 (-0/+10)mm
Shock stroke	55mm
Comp damping	12 Clicks Out
Reb damping	12 Clicks Out
Gas Pressure	10 bar

Part No.	Spring	Rate N/mm	Preload
279S-021-270-029	46-140-120	120	11
279S-021-270-030	46-140-130	130	10
279S-021-270-031	46-140-140	140	9
279S-021-270-032	46-140-155	155	8

## SERVICE

K-Tech Suspension Ltd recommend that this product is serviced every 10,000 miles of use. It is very important that this product is serviced by an authorised dealer, as there are special tools required to guarantee correct performance of this product. K-Tech Suspension Ltd cannot be held responsible for any damage caused to/by the product if a service is overdue or was not conducted by an authorised dealer.





[www.ktechsuspension.com](http://www.ktechsuspension.com)

Contact your local K-Tech dealer for more details at  
[www.ktechsuspension.com/service-centres-and-partners](http://www.ktechsuspension.com/service-centres-and-partners)